

## Low Power CO<sub>2</sub> Sensor

### DESCRIPTION

The CozIR®-LP2 is a low power NDIR CO<sub>2</sub> sensor using state-of-the-art solid-state LED optical technology. The low power LEDs are manufactured in-house, giving GSS complete control of the CO<sub>2</sub> sensor signal chain.

The CozIR®-LP2's low power consumption is compatible with battery powered operation, allowing the sensor to be used in a wide variety of applications including wirelessly connected equipment.

The CozIR®-LP2 operation is configurable depending on user requirements. On power-up, the CozIR®-LP2 automatically starts taking measurements. Measurements can be streamed or output on request.

The CozIR®-LP2 also features a built-in auto-zero function that maintains CO<sub>2</sub> measurement accuracy over the lifetime of the product.

### FEATURES

- Low power CO<sub>2</sub> sensor
- 30ppm typical measurement accuracy
- Solid state NDIR LED optical technology
- UART or I<sup>2</sup>C control and data interface
- Built-in auto-zeroing

### APPLICATIONS

- Air Quality and HVAC
- Building management systems (BMS)
- Demand-Controlled Ventilation (DCV) systems
- IoT and Smart Technology wireless equipment
- Indoor Air Quality (IAQ) equipment

### BLOCK DIAGRAM

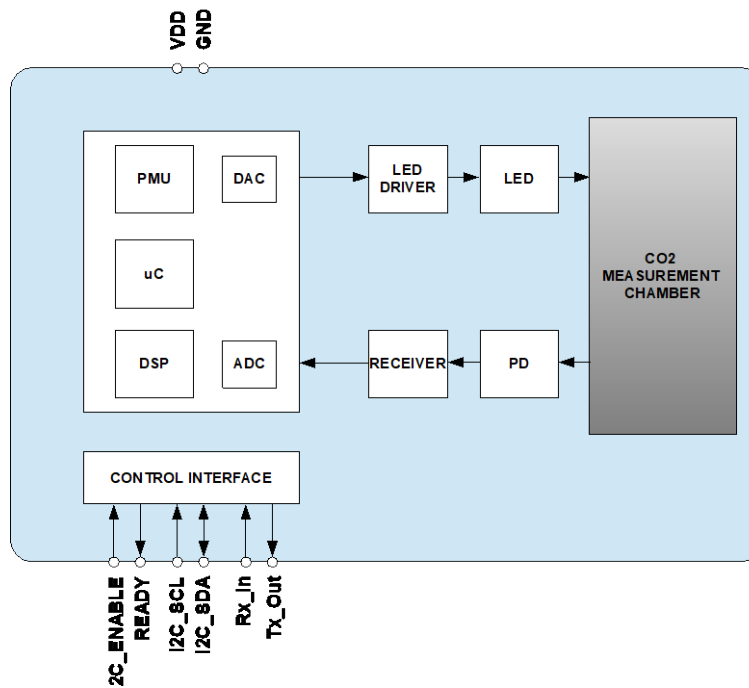

## Low Power CO<sub>2</sub> Sensor

---

### TABLE OF CONTENTS

DESCRIPTION.....	1
BLOCK DIAGRAM.....	1
FEATURES.....	1
APPLICATIONS.....	1
ORDERING INFORMATION.....	5
PACKAGE DRAWING.....	6
PIN-OUT DESCRIPTION.....	7
ABSOLUTE MAXIMUM RATINGS.....	8
RECOMMENDED OPERATING CONDITIONS.....	8
PERFORMANCE CHARACTERISTICS.....	9
ELECTRICAL CHARACTERISTICS.....	9
POWER CONSUMPTION.....	10
METHOD OF OPERATION.....	11
POWER ON DATA READY.....	11
MEASUREMENT CYCLE.....	12
MEASUREMENT CYCLE - I <sup>2</sup> C INTERFACE MODE.....	12
MEASUREMENT CYCLE - UART INTERFACE MODE.....	12
DIGITAL FILTER.....	13
ZERO POINT SETTING.....	14
ZERO IN A KNOWN GAS CONCENTRATION.....	14
ZERO IN NITROGEN.....	14
ZERO IN FRESH AIR.....	14
ZERO POINT ADJUSTMENT (not available in I <sup>2</sup> C interface mode).....	15
AUTO-ZERO FUNCTION.....	15
AUTO-ZERO INTERVALS.....	15
AUTO-ZERO LEVEL.....	15
ALTITUDE COMPENSATION.....	16
ALTITUDE COMPENSATION TABLE.....	16
SELECTION OF CONTROL INTERFACE.....	17
CONTROL INTERFACE TIMING - I <sup>2</sup> C MODE.....	17
I <sup>2</sup> C INTERFACE MODE.....	18
WRITING TO AN I <sup>2</sup> C REGISTER.....	19
READING FROM AN I <sup>2</sup> C REGISTER.....	19
I <sup>2</sup> C REGISTER MAP SUMMARY.....	20
CO <sub>2</sub> LEVEL MEASUREMENT VALUE.....	21
DIGITAL FILTER.....	21
AUTO-ZERO CONTROL.....	21
AUTO-ZERO INITIAL INTERVAL PERIOD.....	22
AUTO-ZERO INTERVAL PERIOD.....	22
AUTO-ZERO TARGET VALUE.....	22
ZERO IN FRESH AIR.....	22
ZERO IN A KNOWN GAS CONCENTRATION.....	23
ALTITUDE COMPENSATION.....	23

## Low Power CO<sub>2</sub> Sensor

---

SERIAL NUMBER.....	23
AUTO-ZERO CONTROL .....	23
CONNECTION DIAGRAM FOR I <sup>2</sup> C INTERFACE.....	24
UART INTERFACE MODE .....	25
CONTROL INTERFACE TIMING - UART MODE .....	25
UART COMMAND PROTOCOL.....	25
UART OPERATION .....	25
METHOD OF OPERATION .....	26
MODE 0 COMMAND MODE .....	26
MODE 1 STREAMING MODE .....	26
MODE 2 POLLING MODE.....	26
K COMMAND.....	26
K COMMAND (0x4B) .....	26
MEASUREMENT DATA OUTPUTS .....	27
UART INTERFACE SUMMARY .....	28
CO <sub>2</sub> LEVEL MEASUREMENT VALUE - Z INFORMATION (0x5A) .....	30
CO <sub>2</sub> LEVEL MEASUREMENT VALUE - z INFORMATION (0x7A) .....	30
CO <sub>2</sub> MEASUREMENT Z SCALING FACTOR – UART MODE.....	30
‘.’ COMMAND (0x2E).....	30
DIGITAL FILTER COMMANDS .....	31
A COMMAND (0x41) .....	31
a COMMAND (0x61).....	31
ZERO SETTING COMMANDS – UART MODE .....	32
G COMMAND (0x47) .....	33
U COMMAND (0x55) .....	33
u COMMAND (0x75) .....	33
X COMMAND (0x58) .....	33
P COMMAND - CO <sub>2</sub> Level for Auto-Zeroing .....	34
P COMMAND – CO <sub>2</sub> Level for Zero-Point Setting.....	34
ALTITUDE COMPENSATION – UART MODE.....	35
S COMMAND (0x53).....	35
s COMMAND (0x73) .....	35
AUTO-ZERO INTERVALS.....	35
@ COMMAND (0x2E) .....	35
SERIAL NUMBER AND FIRMWARE VERSION – UART MODE .....	36
Y COMMAND (0x59).....	36
CONNECTION DIAGRAM FOR UART INTERFACE .....	37
IMPORTANT NOTICE .....	38
ADDRESS .....	38

## Low Power CO<sub>2</sub> Sensor

---

REVISION HISTORY ..... 39

## Low Power CO<sub>2</sub> Sensor

---

### ORDERING INFORMATION

CozIR®-LP2-X



X	Measurement Range
2000	2000ppm
5000	5000ppm
1	10,000ppm (1%)

See separate data sheet for CozIR®-LP2 evaluation kit options.

#### Notes:

1. Sensors are shipped individually or in trays
2. Tray quantity = 50

Low Power CO<sub>2</sub> Sensor

PACKAGE DRAWING

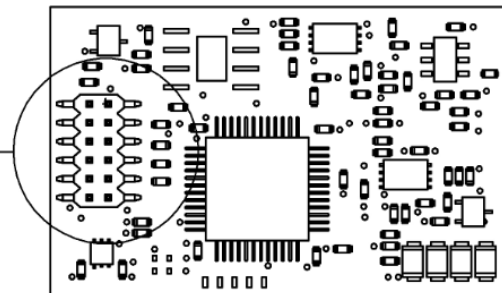
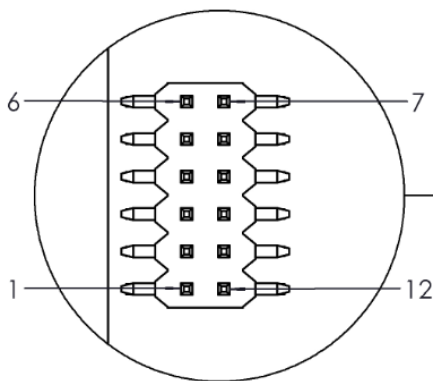
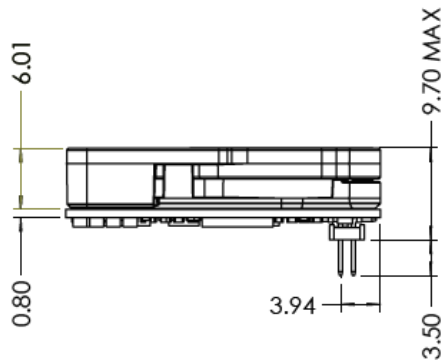
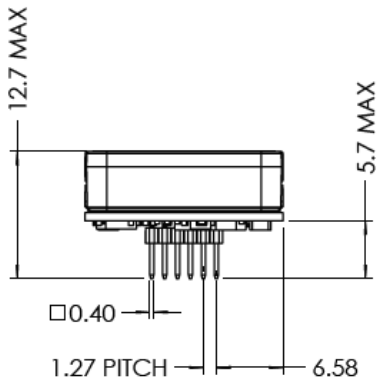
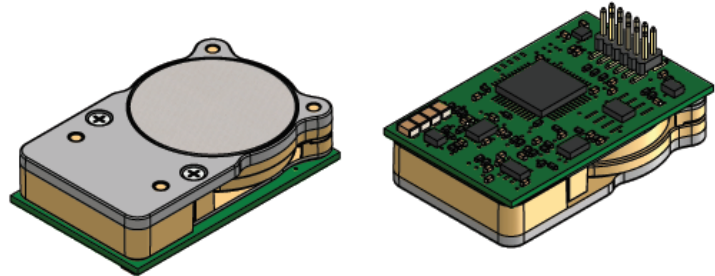
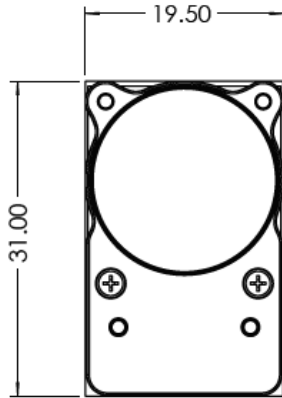

Bottom View

Weight = ~2.5g

## Low Power CO<sub>2</sub> Sensor

---

### PIN-OUT DESCRIPTION

PIN	NAME	TYPE	DESCRIPTION
1	GND	Supply	Sensor ground
2	VDD	Supply	Sensor supply voltage
3	Rx_In	Digital Input	UART Receive Input
4	Tx_Out	Digital Output	UART Transmit Output
5	NC	Unused	Do not connect
6	READY	Digital Output	Data ready pin. Pulsed high when data ready
7	NC	Unused	Do not connect
8	NC	Unused	Do not connect
9	NC	Unused	Do not connect
10	I2C_ENABLE	Digital Input	Set low for I <sup>2</sup> C interface mode. Leave floating to select UART interface mode. Pin status detected at power on.
11	I2C_SCL	Digital Input	I <sup>2</sup> C serial clock input. Open drain, external 4.7kΩ resistor pulled high to VDD required
12	I2C_SDA	Digital Input/Output	I <sup>2</sup> C serial data input/output. Open drain, external 4.7kΩ resistor pulled high to VDD required

## Low Power CO<sub>2</sub> Sensor

### ABSOLUTE MAXIMUM RATINGS

Absolute Maximum Ratings are stress ratings only. Permanent damage to the CozIR®-LP2 may be caused by continuously operating at or beyond these limits. The CozIR®-LP2 functional operating limits and guaranteed performance specifications are given at the test conditions specified.



ESD Sensitive Device. This sensor uses ESD sensitive components. It is therefore generically susceptible to damage from excessive static voltages. Proper ESD precautions must be taken during handling and storage of this device.

CONDITION	MIN	MAX
Supply Voltages	-0.3V	+6.0V
Voltage Range Digital Inputs	GND -0.3V	5V
Operating Temperature Range (T <sub>a</sub> )	0°C	+50°C
Storage Temperature Range	-40°C	+70°C
Humidity Range (RH), non-condensing	0	95%
Operating Ambient Pressure Range	500mbar	2bar

### RECOMMENDED OPERATING CONDITIONS

PARAMETER	SYMBOL	MIN	TYP	MAX	UNIT
Supply	VDD	3.25	3.3	5.5	V
Ground	GND		0		V



## Low Power CO<sub>2</sub> Sensor

**PERFORMANCE CHARACTERISTICS**
**Test Conditions Unless Otherwise Specified**

VDD = 3.3V, GND = 0V. CO<sub>2</sub> = 450ppm, RH = 0% non-condensing, T= 25°C, Pressure = 1013mbar

PARAMETER	SYMBOL	TEST CONDITIONS	MIN	TYP	MAX	UNIT
CO <sub>2</sub> measurement range			0		2,000	ppm
			0		5,000	ppm
			0		10,000	ppm
Accuracy		@25°C		±(30, +3% of reading)	±(45, +3% of reading)	ppm
		0°C to +50°C, after auto-zero @25°C		±(30, +3%), +0.14% per °C		ppm
CO <sub>2</sub> RMS Noise		Digital filter setting 16		6		ppm
Time to Valid Measurement After Power-On		Dependent on filter setting, typ @ 16	0.8	8.3		secs
Response Time		From 0ppm to T <sub>90</sub> (half full-scale), default settings, limited by diffusion through membrane window		30		secs
Repeatability				±(30, +3%)		ppm
Pressure Dependence		Per mbar deviation from 1013mbar, 950-1050mbar		0.14		%
Current Consumption		Peak current when sampling		15		mA
		Peak at turn-on		40		mA
		SLEEP Mode		0.01		mA

**ELECTRICAL CHARACTERISTICS**

PARAMETER	SYMBOL	TEST CONDITIONS	MIN	TYP	MAX	UNIT
<b>Digital Input/Output</b>						
Input HIGH Level			1.8			V
Input LOW Level					1.0	V
Output HIGH Level		I <sub>OH</sub> = +1mA	2.6			V
Output LOW Level		I <sub>OL</sub> = -1mA			0.4	V

## Low Power CO<sub>2</sub> Sensor

### POWER CONSUMPTION

Test Conditions Unless Otherwise Specified

VDD = 3.3V, GND = 0V. CO<sub>2</sub> = 450ppm, RH = 0% non-condensing, T= 25°C, Pressure = 1013mbar

SETTING	SYMBOL	TEST CONDITIONS	VDD		Total Power
			V	I (mA)	mW
OFF		No power applied		0	0
Active, SLEEP mode, no measurement			3.3	0.01	0.03
Active, taking measurements		Average, default settings	3.3	1	3.5

The CozIR®-LP2 current consumption varies in time over the measurement cycle. The LED is pulsed, which results in a peak current when taking measurements of approximately 15mA. A typical current consumption profile after power-on is shown below.

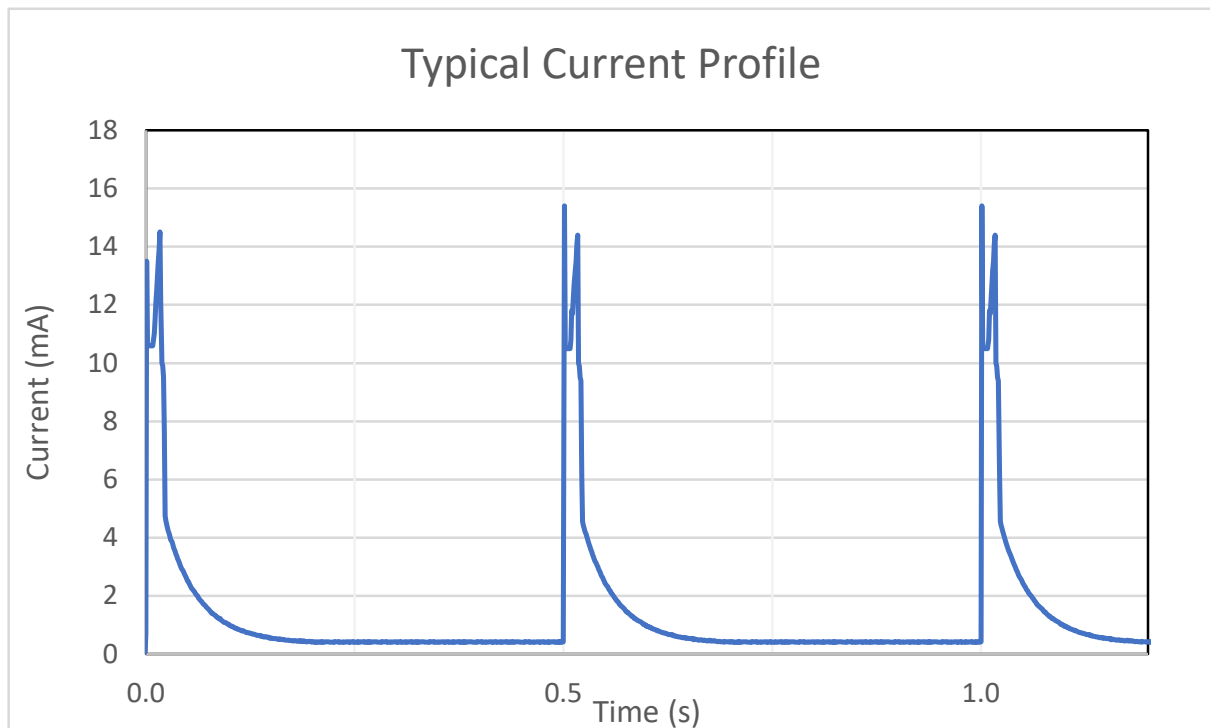

## Low Power CO<sub>2</sub> Sensor

### METHOD OF OPERATION

The CozIR®-LP2 is designed for low power applications where power is often at a premium. When the sensor is switched on, the state of the I2C\_ENABLE pin is sampled. Setting the I2C\_ENABLE pin low puts the CozIR®-LP2 into I<sup>2</sup>C interface mode. Leaving the I2C\_ENABLE pin floating puts the CozIR®-LP2 into UART interface mode.

In UART mode, the sensor automatically starts to automatically take measurements, 2 readings per second. Data can be read out once the READY pin is pulsed high in either UART or I<sup>2</sup>C interface mode.

### POWER ON DATA READY

After power is applied to the CozIR®-LP2, the sensor will automatically start to take CO<sub>2</sub> measurements using the configured settings. Once the initial READY flag has been pulsed high, the sensor will respond to requests for CO<sub>2</sub> data. The control interface is available approximately 14ms after the falling edge of a valid READY pulse.

The data READY time is determined by the digital filter setting.

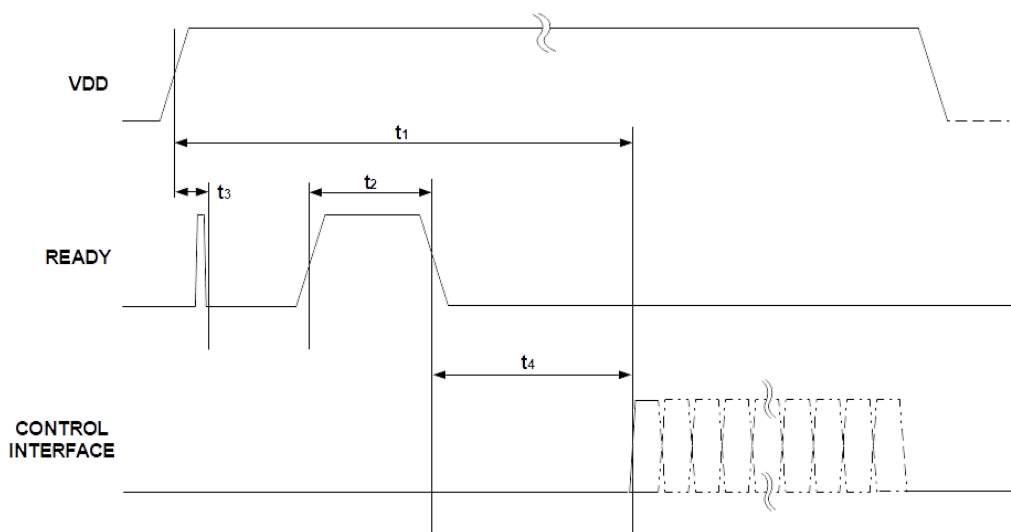

PARAMETER	SYMBOL	MIN	TYP	MAX	UNIT
READY Data Valid from Power On	$t_1$	800			ms
READY High Pulse-Width	$t_2$		16.5		ms
READY Low from Power On	$t_3$			100	ms
Control Interface Setup Time	$t_4$	14			ms

## Low Power CO<sub>2</sub> Sensor

### MEASUREMENT CYCLE

Writing to or reading from the CozIR®-LP3 sensor is gated by the status of the READY pin. In both UART and I<sup>2</sup>C interface mode, the sensor will not respond when the READY pin is high. The READY pin is set high for approximately 16.5ms when the sensor is taking measurements every 0.5 seconds. The control interface is available approximately 14ms after the falling edge of a valid READY pulse. The sensor will only respond correctly when the READY pin is low.

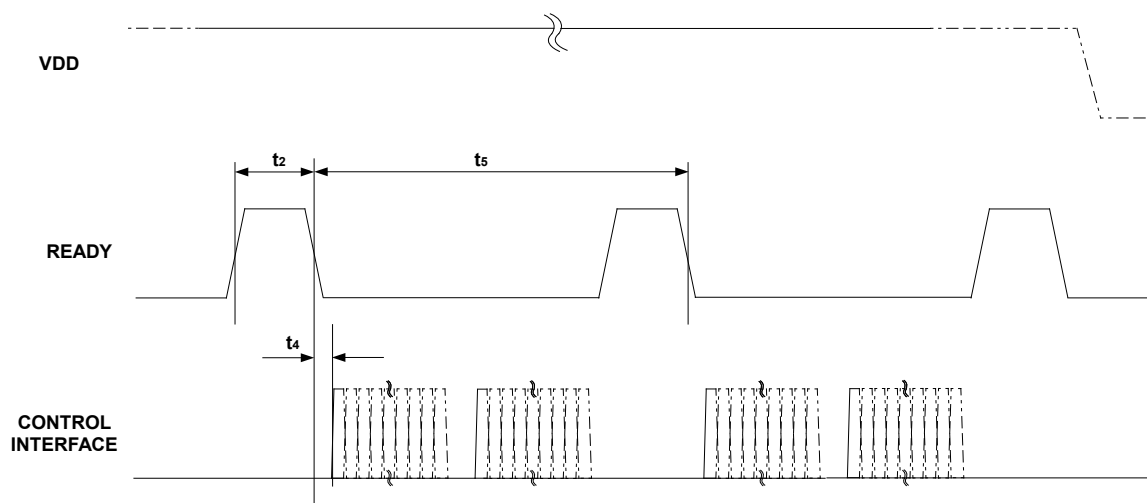

PARAMETER	SYMBOL	MIN	TYP	MAX	UNIT
READY High Pulse-Width	$t_2$		16.5		ms
Control Interface Setup Time	$t_4$	14			ms
READY Pulse Period	$t_5$		0.5		s

### MEASUREMENT CYCLE - I<sup>2</sup>C INTERFACE MODE

- Apply power to the Sensor
- The sensor will automatically start taking measurements.
- Data can be read out at any rate up to the maximum I<sup>2</sup>C read rate
- Measurement data is updated every 0.5 seconds

### MEASUREMENT CYCLE - UART INTERFACE MODE

- Apply power to the Sensor
- The sensor will automatically start taking measurements.
- The sensor takes a measurement at 2 readings per second
- The UART baud rate is fixed at 9600 baud
- Measurement data is updated every 0.5 seconds

## Low Power CO<sub>2</sub> Sensor

### DIGITAL FILTER

The CO<sub>2</sub> gas chamber is illuminated with a nominal 4.25um wavelength LED and the signal received using a photo-diode. The signal from the photo-diode is processed and filtered by the sensor to remove noise and provide an accurate CO<sub>2</sub> reading. High frequency noise coming from the sampling process is removed using a proprietary lowpass filter. The digital filter setting can be varied, allowing the user to reduce measurement noise at the expense of the measurement response time.

The ideal digital filter setting is application specific and is normally a balance between CO<sub>2</sub> reading accuracy and response time. The CozIR®-LP2 sensor will also output the raw unfiltered CO<sub>2</sub> measurement data. This data can be post processed using alternative filter algorithms.

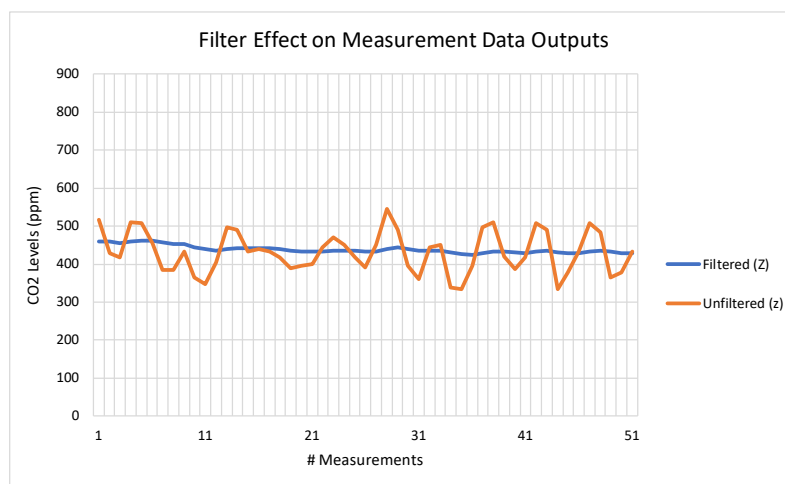

The graph above shows the effects of the filter on the CO<sub>2</sub> measurement data (Z). The unfiltered output (z) is shown in orange and the filtered output (Z) shown in blue.

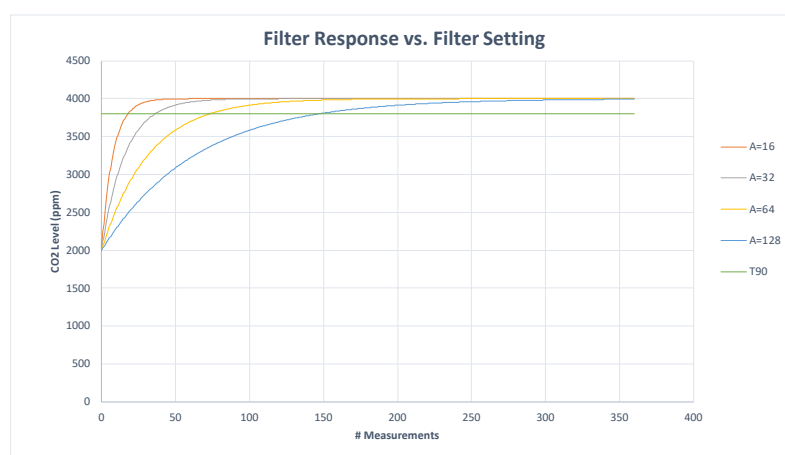

The graph above shows the effect of the filter on response times. Increasing the filter setting increases the measurement output response time. T<sub>90</sub> is the time to 90% of reading. The CozIR®-LP2 takes 2 readings per second. The CozIR®-LP2 sensor will also output the raw unfiltered CO<sub>2</sub> measurement data. This data can be post processed using alternative filter algorithms.

## Low Power CO<sub>2</sub> Sensor

---

### ZERO POINT SETTING

In all cases, the best zero is obtained when the gas concentration is stable, and the sensor is at a stabilised temperature. Zero-point settings are not cumulative and only the latest zero-point setting is effective. For example, there is no benefit in zeroing in nitrogen, and then zeroing in a calibration gas. The sensor will store only the latest zero point regardless of what method is used. There are a several different methods available to the user to set the zero point of the sensor.

### ZERO IN A KNOWN GAS CONCENTRATION

Place the sensor in a known gas concentration and allow time for the sensor temperature to stabilise, and for the gas to be fully diffused into the sensor.

Power up the sensor, wait for the READY pin to indicate the sensor interface is active. Write the known concentration level to the sensor, then initiate the Zero in a Known Gas calibration method. The concentration must be in ppm.

### ZERO IN NITROGEN

Place the sensor in the nitrogen gas and allow time for the sensor temperature to stabilise, and for the gas to be fully diffused into the sensor. Power up the sensor, wait for the READY pin to indicate the sensor interface is active. Initiate the Zero in Nitrogen command. The sensor is zeroed assuming a 0ppm CO<sub>2</sub> environment.

### ZERO IN FRESH AIR

If there is no calibration gas or nitrogen available, the sensor zero point can be set in fresh air. Ambient CO<sub>2</sub> concentrations in fresh air are typically 400ppm. This level is programmable over a range from 0ppm to the full scale of the sensor.

Place the sensor in a fresh air environment and allow time for the sensor temperature to stabilise, and for the fresh air to be fully diffused into the sensor. Power up the sensor, wait for the READY pin to indicate the sensor interface is active.

The user can initiate a Zero in Fresh Air setting cycle. The sensor can use the default fresh air CO<sub>2</sub> concentration value (400ppm), or the user can write a different fresh air value to the sensor if desired. The concentration must be in ppm.

## Low Power CO<sub>2</sub> Sensor

---

### ZERO POINT ADJUSTMENT (not available in I<sup>2</sup>C interface mode)

If the CO<sub>2</sub> concentration and the sensor reported concentrations are known, the zero point can be adjusted using the known concentration to fine tune the zero point. For example, if the sensor has been in an environment that has been exposed to outside air, and the sensor reading is known at that time, the zero point can be fine-tuned to correct the reading. This is typically used to implement automated auto-zeroing routines.

### AUTO-ZERO FUNCTION

The sensor has a built-in auto-zeroing function. To function correctly, the sensor must be exposed to typical background levels (400-450ppm) at least once during the auto-zero period. For example, many buildings will drop quickly to background CO<sub>2</sub> levels when unoccupied overnight or at weekends. The auto-zero function uses the information gathered during these periods to re-zero. The sensor will reset the 'zero' level every time it does an auto-zero. Auto-zeroing is enabled by default. If the sensor is powered down, the auto-zero is reset to default values.

The auto-zero function works in the same way as the **ZERO IN FRESH AIR** command. Auto-zeroing is enabled by default. It is enabled to operate automatically but can be disabled or it can be forced. The user can also independently adjust the CO<sub>2</sub> level used for auto-zeroing. Typically, it is set to the same value as the **ZERO IN FRESH AIR** value, but it can also be set at a different level if desired.

### AUTO-ZERO INTERVALS

The auto-zero period can be programmed by the user. The sensor can be programmed to undertake an initial auto-zero after power-on. Thereafter, the auto-zero period can be set independently of the start-up auto-zero time. Note, the auto-zero settings are reset if the sensor is powered down.

### AUTO-ZERO LEVEL

The background concentration will depend on sensor location. Ambient levels are typically in the range of 400ppm - 450ppm. The factory default is set to 400ppm. The user can change the background ambient level used for auto-zeroing. The value is stored in the sensor.

## Low Power CO<sub>2</sub> Sensor

---

### ALTITUDE COMPENSATION

NDIR gas sensors detect the concentration of gas by measuring the degree of light absorption by the gas analyte. The degree of light absorption is then converted into a concentration reported by the sensor.

The absorption process is pressure dependent, and a change in pressure will cause a change in the reported gas concentration. As the pressure increases, the reported gas concentration also increases. As the pressure decreases, the reported concentration decreases. This effect takes place at a molecular level and is common to all NDIR gas sensors.

GSS sensors are calibrated at 1013mbar. The reading will vary by approximately 0.14% of reading for each mbar change in barometric pressure.

If the sensor is installed at an elevated altitude, the mean barometric pressure will be lower than 1013mbar. It is possible to configure the sensor to correct for this effect, by setting the altitude compensation value as part of the initial set up process. This will apply a permanent correction to the output of the sensor, depending on the altitude setting selected.

### ALTITUDE COMPENSATION TABLE

Altitude (ft.)	Altitude (m)	Pressure (mbar)	Sea Level Difference	% Change per	CO <sub>2</sub> Measurement Change (%)	Compensation Value
0	0	1,013	0	0.14	0	8,192
500	153	995	18	0.14	3	8,398
1,000	305	977	36	0.14	5	8,605
1,500	458	960	53	0.14	7	8,800
2,000	610	942	71	0.14	10	9,006
2,500	763	925	88	0.14	12	9,201
3,000	915	908	105	0.14	15	9,396
3,500	1,068	891	122	0.14	17	9,591
4,000	1,220	875	138	0.14	19	9,775
4,500	1,373	859	154	0.14	22	9,958
5,000	1,525	843	170	0.14	24	10,142
6,000	1,830	812	201	0.14	28	10,497
7,000	2,135	782	231	0.14	32	10,841
8,000	2,440	753	260	0.14	36	11,174
9,000	2,745	724	289	0.14	40	11,506
10,000	3,050	697	316	0.14	44	11,816

Other altitude compensation values can be calculated using the following formula.

$$\text{Compensation Value} = 8192 + \left( \frac{\text{Sea Level Difference} * 0.14}{100} \right) * 8192$$



## Low Power CO<sub>2</sub> Sensor

### SELECTION OF CONTROL INTERFACE

The CozIR®-LP2 is controlled by writing to registers through a serial control interface. The control interface can be configured as a UART or 2-wire I<sup>2</sup>C interface.

Selection of the control interface is done via the I2C\_ENABLE pin. The state of the I2C\_ENABLE pin is sampled at power up only. The status cannot be changed after power up. Setting the I2C\_ENABLE pin low puts the CozIR®-LP2 into I<sup>2</sup>C interface mode. Leaving the I2C\_ENABLE pin floating puts the CozIR®-LP2 into UART control interface mode.

### CONTROL INTERFACE TIMING - I<sup>2</sup>C MODE

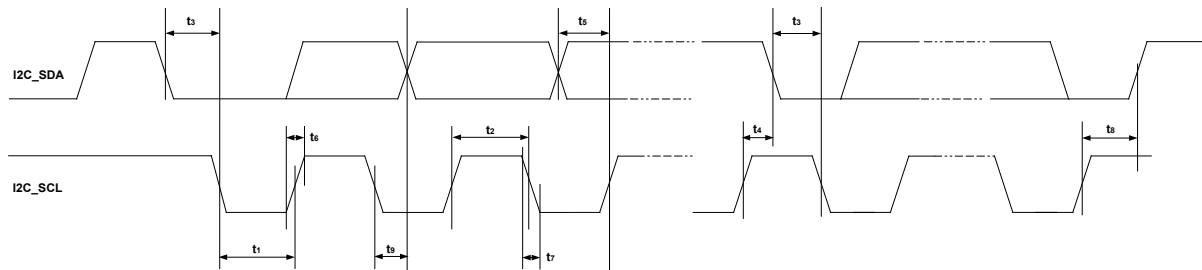

PARAMETER	SYMBOL	MIN	TYP	MAX	UNIT
I2C_SCL Frequency		0		100	kHz
I2C_SCL Low Pulse-Width	t <sub>1</sub>	4.7			us
I2C_SCL High Pulse-Width	t <sub>2</sub>	4.0			us
Hold Time (Start Condition)	t <sub>3</sub>	4.0			us
Setup Time (Start Condition)	t <sub>4</sub>	4.7			us
Data Setup Time	t <sub>5</sub>	250			ns
I2C_SDA, I2C_SCL Rise Time	t <sub>6</sub>			1000	ns
I2C_SDA, I2C_SCL Fall Time	t <sub>7</sub>			300	ns
Setup Time (Stop Condition)	t <sub>8</sub>	4.0			us
Data Hold Time	t <sub>9</sub>	0		5.0	us
Capacitive load for each bus line	-			400	pF

## Low Power CO<sub>2</sub> Sensor

---

### I<sup>2</sup>C INTERFACE MODE

The CozIR®-LP2 supports software control via a 2-wire serial bus. Many devices can be controlled by the same bus, and each device has a unique 7-bit address (this is not the same as the 8-bit address of each register in the CozIR®-LP2). The CozIR®-LP2 operates as a slave only device.

The controller indicates the start of data transfer with a high to low transition on I2C\_SDA while I2C\_SCL remains high (I<sup>2</sup>C Start condition). This indicates that a device address will follow. All devices on the 2-wire bus respond to the start condition and shift in the next eight bits on I2C\_SDA (7-bit address + Read/Write bit, MSB first). If the device address received matches the address of the CozIR®-LP2 and the R/W bit is '0', indicating a write, then the CozIR®-LP2 responds by pulling I2C\_SDA low on the next clock pulse (ACK). If the address is not recognised or the R/W bit is '1', the CozIR®-LP2 returns to the idle condition and waits for a new start condition and valid address.

The CozIR®-LP2 acknowledges the correct address by pulling I2C\_SDA low for one clock pulse. The master then sends the address of the register it wishes to read from or write to. Data is either read from or written to in 1 - 4 bytes, most significant byte (MSB) first.

The transfer of data is complete when there is a low to high transition on I2C\_SDA while I2C\_SCLK is high. After receiving a complete address and data sequence the CozIR®-LP2 returns to the idle state and waits for another start condition. If a start or stop condition is detected out of sequence at any point during data transfer (i.e. I2C\_SDA changes while I2C\_SCL is high), the device jumps to the idle condition.

***The CozIR®-LP2 device address is 0x41.***

## Low Power CO<sub>2</sub> Sensor

### WRITING TO AN I<sup>2</sup>C REGISTER

The controller (Master) sends a START condition to the sensor. The sensor acknowledges the controller by setting the R/W bit low, indicating it is expecting the controller to write to a register. The controller sends the register address that it wants to write to, and then 1-4 data bytes. Once the controller has completed the operation, it sends the STOP condition.

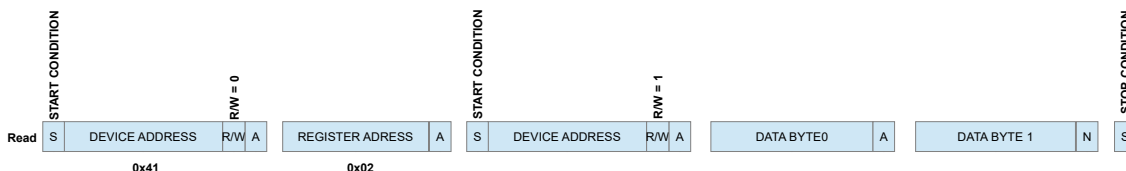

### READING FROM AN I<sup>2</sup>C REGISTER

The controller (Master) sends a START condition to the sensor. The sensor acknowledges the controller by setting the R/W bit high, indicating it is expecting the controller to read from a register. The controller sends the register address that it wants to read from, and then reads out 1-4 data bytes. Once the controller has completed the operation, it sends the STOP condition.

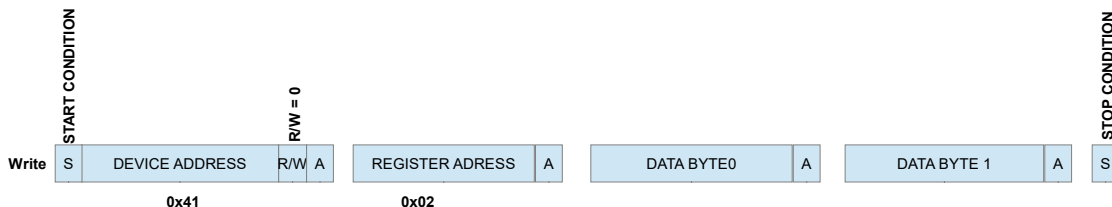

## Low Power CO<sub>2</sub> Sensor

**I<sup>2</sup>C REGISTER MAP SUMMARY**

REGISTER	ADDRESS	DESCRIPTION	DEFAULT	RANGE	Size (bytes)	READ/WRITE
R2 (0x02)	00000010	CO <sub>2</sub> Level (ppm)	N/A	0 – 65535	2	READ only
R4 (0x04)	00000100	Digital Filter Setting	16	0 - 256	1	READ/WRITE*
R5 (0x05)	00000101	Sensor Control Settings			1	WRITE only
R6 (0x06)	00000110	Auto-Zero Initial Interval Period	12096	0 - 65535	2	READ/WRITE
R8 (0x08)	00001000	Auto-Zero Interval Period	13824	0 - 65535	2	READ/WRITE
R12 (0x0C)	00001100	Auto-Zero Target Level	400ppm	0 to full scale	2	READ/WRITE
R18 (0x12)	00010010	Target value for CO <sub>2</sub> in fresh air (in ppm)	400ppm	0 to full scale	2	READ/WRITE
R20 (0x14)	00010100	Known CO <sub>2</sub> Concentration (in ppm)		0 to full scale	2	READ/WRITE
R30 (0x1E)	00011110	Altitude Correction Value	8192	0 to 32768	2	READ/WRITE
R38 (0x26)	00100110	Serial Number	N/A		4	READ only
R78 (0x4E)	01001110	Auto-Zero Control			1	READ/WRITE*

\* indicates a sensor zero should be performed after the default values are changed.

## Low Power CO<sub>2</sub> Sensor

---

### CO<sub>2</sub> LEVEL MEASUREMENT VALUE

REGISTER	ADDRESS	BIT	LABEL	DESCRIPTION	DEFAULT	READ/WRITE
R2 (0x02)	00000010	15:0		CO <sub>2</sub> level, in ppm		Read only

The measured CO<sub>2</sub> level is read from Register R2, 2 bytes, MSB first. The value is CO<sub>2</sub> level in ppm.

### DIGITAL FILTER

REGISTER	ADDRESS	BIT	LABEL	DESCRIPTION	DEFAULT	READ/WRITE
R4 (0x04)	00000100	7:0	FILTER	Digital filter setting	00010000	Read/Write

### AUTO-ZERO CONTROL

REGISTER	ADDRESS	BIT	LABEL	DESCRIPTION	DEFAULT	READ/WRITE
R5 (0x05)	00000101	0	Air Zero	Sets the zero point assuming the sensor is in 400ppm CO <sub>2</sub> . Write the measured CO <sub>2</sub> level into Register 18  00000000: No Zero 00000001: Zero	00000000	Write
		2	X Zero	Sets the zero point with the sensor in a known concentration of CO <sub>2</sub> . Write the target ppm concentration into Register 20.  00000000: No X Zero 00000010: X Zero	00000000	Write

## Low Power CO<sub>2</sub> Sensor

---

### AUTO-ZERO INITIAL INTERVAL PERIOD

REGISTER	ADDRESS	BIT	LABEL	DESCRIPTION	DEFAULT	READ/WRITE
R6 (0x06)	00000110	15:0		Sets the auto-zero initial interval count period. Each count is 0.5s.	10111101000000	Read/Write

The interval period format is defined by the number of measurements periods. For the CozIR®-LP2, the measurement period is 0.5seconds. The default initial auto-zero period value is 12,096 measurement periods, = 6,048 seconds (100.8 minutes).

### AUTO-ZERO INTERVAL PERIOD

REGISTER	ADDRESS	BIT	LABEL	DESCRIPTION	DEFAULT	READ/WRITE
R8 (0x08)	00001000	15:0		Sets the auto-zero interval period	11011000000000	Read/Write

The interval period format is defined by the number of measurements periods. For the CozIR®-LP2, the measurement period is 0.5seconds. The default value is 13,824 measurement periods, = 6,912 seconds (115.2 minutes).

### AUTO-ZERO TARGET VALUE

REGISTER	ADDRESS	BIT	LABEL	DESCRIPTION	DEFAULT	READ/WRITE
R12 (0x0C)	00000010	15:0		Sets the target value for CO <sub>2</sub> level when doing an auto-zeroing	110010000	Read/Write

The user can independently set the target value for CO<sub>2</sub> used for an auto-zero event. The default is 400ppm.

### ZERO IN FRESH AIR

REGISTER	ADDRESS	BIT	LABEL	DESCRIPTION	DEFAULT	READ/WRITE
R18 (0x12)	00010010	15:0		Target value for CO <sub>2</sub> in fresh air	110010000	Read/Write

The target value for CO<sub>2</sub> in fresh air is stored in register 18. The default is 400ppm.

## Low Power CO<sub>2</sub> Sensor

---

### ZERO IN A KNOWN GAS CONCENTRATION

REGISTER	ADDRESS	BIT	LABEL	DESCRIPTION	DEFAULT	READ/WRITE
R20 (0x14)	00010100	15:0	X Zero	CO <sub>2</sub> concentration (in ppm)		Read/Write

Stores the target ppm concentration of CO<sub>2</sub> gas. All CO<sub>2</sub> values are in ppm. CO<sub>2</sub> level is a two-byte value, MSB first.

### ALTITUDE COMPENSATION

REGISTER	ADDRESS	BIT	LABEL	DESCRIPTION	DEFAULT	READ/WRITE
R30 (0x1E)	00011110	15:0	ALTITUDE	Altitude level compensation value	10000000000000	Read/Write

### SERIAL NUMBER

REGISTER	ADDRESS	BIT	LABEL	DESCRIPTION	DEFAULT	READ/WRITE
R38 (0x26)	00100110	31:0	SERIAL NUMBER	Unique sensor serial number, 32-digit code		Read only

### AUTO-ZERO CONTROL

REGISTER	ADDRESS	BIT	LABEL	DESCRIPTION	DEFAULT	READ/WRITE
R78 (0x4E)	01001110	7:0	AUTO CAL	Auto-zero control  00000000 = Disabled  00000010 = Enabled	00000010	Read/Write

To force an auto-zeroing sequence, do the following.

- Set R78 to Enabled
- Set R12 auto-zero to target level, or leave at its default setting
- Set R8 interval period to zero

## Low Power CO<sub>2</sub> Sensor

### CONNECTION DIAGRAM FOR I<sup>2</sup>C INTERFACE

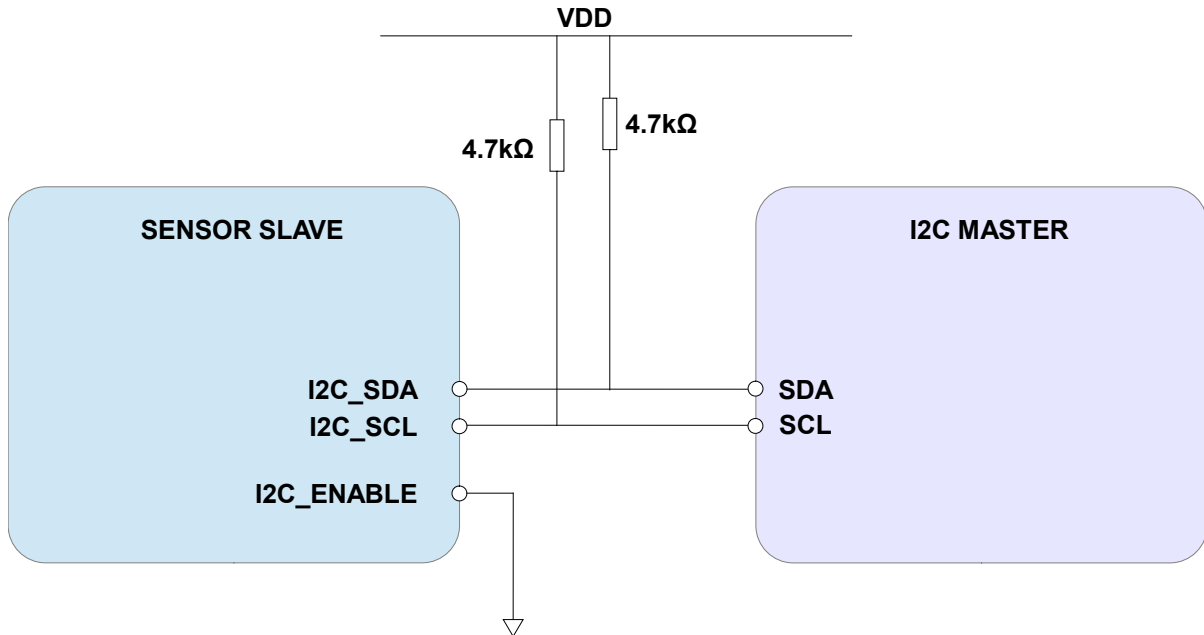



## Low Power CO<sub>2</sub> Sensor

### UART INTERFACE MODE

Leaving the I<sup>2</sup>C\_ENABLE pin floating puts the CozIR®-LP2 into UART control interface mode. The status of the I<sup>2</sup>C\_ENABLE is only sampled at power up.

The Rx\_In and Tx\_Out pins are normally high, suitable for direct connection to a UART. If the sensor is to be read by a true RS232 device (e.g. a PC), it is necessary to use a level converter to step up/down the voltage and invert the signal.

### CONTROL INTERFACE TIMING - UART MODE

PARAMETER	SYMBOL	MIN	TYP	MAX	UNIT
Baud Rate (Fixed)			9,600		Bits/s
Data Bits			8		
Parity			None		
Stop Bits			1		
Hardware Flow Control			None		

### UART COMMAND PROTOCOL

All UART commands must be terminated with a carriage return and line feed <CR><LF>, hex 0x0D 0x0A. In this document, this is shown as '\r\n'. UART commands that take a parameter always have a space between the letter and the parameter. The sensor will respond with a '?' if a command is not recognised. The two most common causes are missing spaces or missing <CR><LF> terminators.

All command communications are in ASCII and are terminated by carriage return, line feed (0x0D 0x0A). This document uses the protocol "\r\n" to indicate the carriage return line feed. All responses from the sensor, including measurements, have a leading space (ASCII character 32).

The character '#' represents an ASCII representation of a numeric character (0-9). Note there is a space between the first letter and any parameter. For example, the X command reads "X space 2000 carriage return line feed".

### UART OPERATION

When initially powered, the sensor will immediately start to transmit a CO<sub>2</sub> reading on receiving any character. The sensor will also output a reading based on receiving any character, used mostly when in K 2 mode.

The CO<sub>2</sub> measurement is reported as:

Z #####\r\n

where Z ##### shows the CO<sub>2</sub> concentration.

Note that all outputs from the sensor have a leading space.

## Low Power CO<sub>2</sub> Sensor

---

### METHOD OF OPERATION

After power is applied to the CozIR-LP2®, the sensor will automatically start to take CO<sub>2</sub> measurements using the Mode 1 default settings, where the sensor is pre-programmed to send CO<sub>2</sub> measurement data at 2 readings per second. The measurement rate is fixed at 2 readings per second at 9600 baud rate. The sensor will return the previous CO<sub>2</sub> measurement results if the user requests more frequent measurements. The CozIR-LP2® has 3 potential modes of operation.

### MODE 0 COMMAND MODE

In this mode, the sensor is in a SLEEP mode, waiting for commands. No measurements are made. There is no latency in command responses. All commands that report measurements or alter the zero-point settings are disabled in Mode 0. Mode 0 is NOT retained after power cycling.

### MODE 1 STREAMING MODE

This is the factory default setting. Measurements are reported twice per second. Commands are processed when received, except during measurement activity, so there may be a time delay of up to 100ms in responding to commands.

### MODE 2 POLLING MODE

In polling mode, the sensor only reports readings when requested. The sensor will continue to take measurements in the background, but the output stream is suppressed until data is requested. The sensor will always power up in streaming or polling mode, whichever mode was used before the power cycle.

### K COMMAND

Command	Use	Default	Range	Example	Response	Comments
K #\r\n	Switches the sensor between different control modes, K1, 2 or 3	1		K 1\r\n	K 1\r\n	<i>See 'K' Commands</i>

### K COMMAND (0x4B)

<b>Description</b>	Sets the control interface mode
<b>Syntax</b>	ASCII character 'K', SPACE, mode number, terminated by 0x0D 0x0A (CR & LF)
<b>Example</b>	K 1\r\n
<b>Response</b>	K 00001\r\n (this number is variable)

## Low Power CO<sub>2</sub> Sensor

### MEASUREMENT DATA OUTPUTS

The CozIR®-LP2 sensor can be configured to provide filtered and unfiltered CO<sub>2</sub> data as a single string of data. The number of data sets being sent by the sensor is configurable using the ‘M’ command. Up to 5 different data sets can be transmitted in one string.

UART Command	Use	Default	Range	Example	Response	Comments
M #####\r\n	Sets the number of measurement data types output by the sensor. Set ##### to the mask value	M 00006\r\n		See “Output Fields”	M #####\r\n	Sets the number of measurement data types output by the sensor

Measurement Parameter	Field Identifier	Mask Value
CO <sub>2</sub> (Filtered)	Z	4
CO <sub>2</sub> (Unfiltered)	z	2

The CO<sub>2</sub> measurement string is reported as:

Z ##### z #####\r\n

where

Z ##### shows the CO<sub>2</sub> concentration after digitally filtering

and

z ##### shows the instantaneous CO<sub>2</sub> concentration without any digital filtering.

The required mask value is the sum of the ‘Mask Value’ for each field required. To output filtered and unfiltered CO<sub>2</sub> data, set M=6.

## Low Power CO<sub>2</sub> Sensor

**UART INTERFACE SUMMARY**

Syntax	Use	Example	Response	Comments
A ###\r\n	Set value of the digital filter, nPulse	A 128\r\n	A 00128\r\n	See “ <b>Digital Filter</b> ”
a\r\n	Return the value of the digital filter, nPulse	a\r\n	a 00128\r\n	See “ <b>Digital Filter</b> ”
G\r\n	Zero-point setting using fresh air	G\r\n	G 33000\r\n	See “ <b>Zero Point Setting</b> ”
K #\r\n	Switches the sensor between different modes	K 1\r\n	K 1\r\n	
M ###\r\n	Sets the number of measurement data types output by the sensor	M 6\r\n	M 6\r\n	See “ <b>Output Fields</b> ”
P 8 ###\r\n P 9 #\r\n	Sets value of CO <sub>2</sub> background concentration in ppm for auto-zeroing	P 8 1\r\n P 9 144\r\n		Two-byte value, P 8 = MSB P 9 = LSB  400ppm in the example
P 10 ###\r\n P 11 #\r\n	Sets value of CO <sub>2</sub> background concentration in ppm used for zero-point setting in fresh air.	P 10 1\r\n P 11 144\r\n		Two-byte value, P 10 = MSB P 11 = LSB  400ppm in the example
Q\r\n	Reports the latest measurement data types, as defined by ‘M’	Q\r\n	H 12345 T 12345 Z 00010\r\n	
S #####\r\n	Sets the altitude compensation value	S 8192\r\n	S 08192\r\n	See “ <b>Altitude Compensation</b> ”
s\r\n	Returns the altitude compensation value	s\r\n	s 08192\r\n	See “ <b>Altitude Compensation</b> ”
U\r\n	Zero-point setting using nitrogen	U\r\n	U 33000\r\n	See “ <b>Zero Point Setting</b> ”
u #####\r\n	Manual setting of the zero point.	u 32997\r\n	u 32997\r\n	See “ <b>Zero Point Setting</b> ”
X #####\r\n	Zero-point setting using a known gas calibration	X 2000\r\n	X 32997\r\n	See “ <b>Zero Point Setting</b> ”
Y\r\n	Returns firmware version and sensor serial number	Y\r\n	Returns <u>two</u> lines	
Z\r\n	Returns the most recent filtered CO <sub>2</sub> measurement in ppm	Z\r\n	Z 00521\r\n	

## Low Power CO<sub>2</sub> Sensor

Syntax	Use	Example	Response	Comments
z\r\n	Returns the most recent unfiltered CO <sub>2</sub> measurement in ppm	z\r\n	Z 00521\r\n	
@ ## ##\r\n	Sets the timing for initial and interval auto-zero periods	@ 1.0 8.0\r\n	@ 1.0 8.0\r\n	See <b>"Auto-Zero Function"</b> for details
@ r\r\n	Returns the Auto-zero configuration	@ 1.0 8.0\r\n	@ 1.0 8.0\r\n	See <b>"Auto-Zero Function"</b> for details
@ #r\r\n	Switch Auto-Zeroing on or off	@ 0\r\n	@ 0\r\n	See <b>"Auto-Zero Function"</b> for details
.\r\n	Returns the scaling factor multiplier required to convert the Z or z output to ppm	.\r\n	. 00001\r\n	Multiply by 1 in the example

## Low Power CO<sub>2</sub> Sensor

---

### CO<sub>2</sub> LEVEL MEASUREMENT VALUE - Z INFORMATION (0x5A)

<b>Description</b>	Reports the latest filtered CO <sub>2</sub> measurement
<b>Syntax</b>	ASCII Character 'Z', terminated by 0x0D 0x0A (CR & LF)
<b>Example</b>	Z\r\n
<b>Response</b>	Z 00521\r\n

This value needs to be multiplied by the appropriate multiplier to get the ppm value.

### CO<sub>2</sub> LEVEL MEASUREMENT VALUE - z INFORMATION (0x7A)

The sensor is also capable of reporting the real time unfiltered CO<sub>2</sub> measurement value.

<b>Description</b>	Reports the unfiltered CO <sub>2</sub> measurement
<b>Syntax</b>	ASCII Character 'z', terminated by 0x0D 0x0A (CR & LF)
<b>Example</b>	z\r\n
<b>Response</b>	z 00521\r\n

### CO<sub>2</sub> MEASUREMENT Z SCALING FACTOR – UART MODE

To calculate the measurement value in ppm, the 'Z' or 'z' value must be converted into ppm by using the '.' multiplier factor. The multiplier will depend on the full-scale measurement range of the sensor.

Measurement Range of Sensor	CO <sub>2</sub> Measurement Scaling Factor (Z)	CO <sub>2</sub> Measurement Output Units	Example
0 – 1%	1	ppm	Z 00521 = 521ppm

### '.' COMMAND (0x2E)

To calculate the measurement value in ppm, the 'Z' or 'z' value must be converted into ppm by using the '.' multiplier factor. This multiplier will depend on the full-scale measurement range of the sensor. The multiplier is related to the full-scale range of the sensor. The multiplier must also be used when sending CO<sub>2</sub> concentration levels to the sensor, for example when setting the fresh air CO<sub>2</sub> concentration value. The '.' Command can also be used to read back the scaling factor.

<b>Description</b>	Returns a number indicating what multiplier must be applied to the Z CO <sub>2</sub> measurement output to convert it into ppm.
<b>Syntax</b>	ASCII character '.', terminated by 0x0D 0x0A ( CR & LF )
<b>Example</b>	.\r\n
<b>Response</b>	. 00001\r\n (this number is always 1 for CozIR®-LP2)

## Low Power CO<sub>2</sub> Sensor

---

**DIGITAL FILTER COMMANDS**

Command	Use	Default	Range	Example	Response	Comments
A ###\r\n	Set value of the digital filter	16	0 - 65635	A 16\r\n	A 00016\r\n	
a\r\n	Return value of digital filter		0 - 65365	a\r\n	a 00016\r\n	

**A COMMAND (0x41)**

<b>Description</b>	Set the value of the digital filter
<b>Syntax</b>	ASCII character 'A', SPACE, decimal, terminated by 0x0D 0x0A (CR & LF)
<b>Example</b>	A 16\r\n
<b>Response</b>	A 00016\r\n (this number is variable)

**a COMMAND (0x61)**

<b>Description</b>	Read the value of the digital filter
<b>Syntax</b>	ASCII character 'A', SPACE, decimal, terminated by 0x0D 0x0A (CR & LF)
<b>Example</b>	A 16\r\n
<b>Response</b>	A 00016\r\n (this number is variable)

## Low Power CO<sub>2</sub> Sensor

### ZERO SETTING COMMANDS – UART MODE

Command	Use	Default	Range	Example	Response	Comments
G\r\n	Zero-point setting using fresh air			G\r\n	G 33000\r\n	See <b>“Zero-Point Setting”</b>
U\r\n	Zero-point setting using nitrogen			U\r\n	U 33000\r\n	See <b>“Zero Point Setting”</b>
u #####\r\n	Manual setting of the zero point			u 32997\r\n	u 32997\r\n	See <b>“Zero Point Setting”</b>
X #####\r\n	Zero-point setting using a known gas concentration (in ppm)			X 1000\r\n	X 32997\r\n	See <b>“Zero Point Setting”</b>
P 8 ###\r\n P 9 #\r\n	Sets value of CO <sub>2</sub> background concentration in ppm for auto-zeroing	P 8 1\r\n P 9 144\r\n		Two-byte value P 8 = MSB P 9 = LSB  400ppm in the example	P 8 ###\r\n P 9 ###\r\n	
P 10 ###\r\n P 11 #\r\n	Sets value of CO <sub>2</sub> background concentration in ppm used for zero-point setting in fresh air.	P 10 1\r\n P 11 144\r\n		Two-byte value P 10 = MSB P 11 = LSB  400ppm in the example	P 10 ###\r\n P 11 ###\r\n	



## Low Power CO<sub>2</sub> Sensor

---

**G COMMAND (0x47)**

<b>Description</b>	Calibrates the zero point assuming the sensor is in fresh air (typically 400ppm CO <sub>2</sub> , but level can be set by user – see P commands.)
<b>Syntax</b>	ASCII character 'G' terminated by 0x0D 0x0A (CR & LF)
<b>Example</b>	G\r\n
<b>Response</b>	G 33000\r\n (the number is variable)

**U COMMAND (0x55)**

<b>Description</b>	Calibrates the zero point assuming the sensor is in 0ppm CO <sub>2</sub> such as nitrogen.
<b>Syntax</b>	ASCII Character 'U' terminated by 0x0D 0x0A (CR & LF)
<b>Example</b>	U\r\n
<b>Response</b>	U 32767\r\n (the number is variable)

**u COMMAND (0x75)**

<b>Description</b>	Forces a specific zero set point value. Input value is scaled by CO <sub>2</sub> value multiplier, see '.' command.
<b>Syntax</b>	ASCII character 'u', SPACE, then the gas concentration, terminated by 0x0D 0x0A (CR & LF)
<b>Example</b>	u 32767\r\n
<b>Response</b>	u 32767\r\n

**X COMMAND (0x58)**

<b>Description</b>	Calibrates the zero point with the sensor in a known concentration of CO <sub>2</sub> . Input value is scaled by CO <sub>2</sub> value multiplier, see '.' command.
<b>Syntax</b>	ASCII character 'X', SPACE, then the gas concentration, terminated by 0x0D (CR & LF)
<b>Example</b>	X 1000\r\n
<b>Response</b>	X 33000\r\n (the number is variable).

## Low Power CO<sub>2</sub> Sensor

---

### P COMMAND - CO<sub>2</sub> Level for Auto-Zeroing

<b>Description</b>	Sets the value of CO <sub>2</sub> in ppm used for auto-zeroing. Input value is scaled by CO <sub>2</sub> value multiplier, see '.' command.
<b>Syntax</b>	ASCII character 'P', SPACE, then 8, SPACE, then MSB terminated by 0x0D 0x0A (CR & LF)  ASCII character 'P' then a space, then 9, then a space, then LSB terminated by 0x0D 0x0A (CR & LF)
<b>Example</b>	P 8 0\r\n P 9 40\r\n
<b>Response</b>	p 8 0\r\n p 9 40\r\n

The value is entered as a two-byte word, MSB first.

MSB = Integer (Concentration/256)

LSB = Concentration – (256\*MSB)

In the above example, target CO<sub>2</sub> background concentration is 400ppm.

MSB = Integer (400/256) = 1

LSB = 400 – 256 = 144

### P COMMAND – CO<sub>2</sub> Level for Zero-Point Setting

<b>Description</b>	Sets value of CO <sub>2</sub> in ppm for zero-point setting in fresh air.
<b>Syntax</b>	ASCII character 'P' then a space, then 10, then a space, then MSB terminated by 0x0D 0x0A (CR & LF)  ASCII character 'P' then a space, then 11, then a space, then LSB terminated by 0x0D 0x0A (CR & LF)
<b>Example</b>	P 10 7\r\n P 11 208\r\n
<b>Response</b>	P 00010 00007\r\n P 00011 00208\r\n

MSB = Integer (Concentration/256)

LSB = Concentration – (256\*MSB)

In the above example, target zero-point CO<sub>2</sub> concentration is 2000ppm.

MSB = Integer (2000/256) = 7

LSB = 2000 – (256\*MSB) = 208

## Low Power CO<sub>2</sub> Sensor

### ALTITUDE COMPENSATION – UART MODE

UART Command	Use	Default	Range	Example	Response	Comments
S #####\r\n	Sets the altitude compensation value	8192	0-65536	S 8192\r\n	S 08192\r\n	See “ <i>Altitude Compensation</i> ”
s\r\n	Returns the altitude compensation value			s\r\n	s 08192\r\n	See “ <i>Altitude Compensation</i> ”

### S COMMAND (0x53)

<b>Description</b>	Set the ‘Altitude Compensation’ value
<b>Syntax</b>	ASCII character 'S', SPACE, decimal, terminated by 0x0D 0x0A (CR & LF)
<b>Example</b>	S 8192\r\n
<b>Response</b>	S 8192\r\n (the number mirrors the input value)

### s COMMAND (0x73)

<b>Description</b>	Reports the ‘Altitude Compensation’ value.
<b>Syntax</b>	ASCII Character 's', terminated by 0x0D 0x0A (CR & LF)
<b>Example</b>	s\r\n
<b>Response</b>	s 8192\r\n

### AUTO-ZERO INTERVALS

UART Command	Use	Default	Range	Example	Response	Comments
@ #.#.#.#\r\n	Auto-zero interval settings			@ 1.0 8.0\r\n	@ 1.0 8.0\r\n	See “Auto-Zero Function” for details

### @ COMMAND (0x2E)

<b>Description</b>	Set the ‘Initial Interval’ and ‘Regular Interval’ for auto-zero events.
<b>Syntax</b>	ASCII character '@', SPACE, decimal, SPACE, decimal terminated by 0x0D 0x0A (CR & LF)
<b>Example</b>	@ 1.0 8.0\r\n
<b>Response</b>	@ 1.0 8.0\r\n (the number mirrors the input value)

Both the initial interval and regular interval are given in days. Both must be entered with a decimal point and one figure after the decimal point. In the above example, the auto-zero interval is set to 8 days, and the initial interval set to 1 day.

To disable auto-zeroing, send @ 0\r\n.

To start an auto-zeroing immediately, send 65222\r\n.

To determine the auto-zero configuration, send @\r\n.

## Low Power CO<sub>2</sub> Sensor

---

### SERIAL NUMBER AND FIRMWARE VERSION – UART MODE

UART Command	Use	Default	Range	Example	Response	Comments
Y\r\n	Return firmware version and sensor serial number			Y\r\n	Returns <u>two</u> lines	

### Y COMMAND (0x59)

<b>Description</b>	The present version string for the firmware and serial number of the sensor.
<b>Syntax</b>	ASCII character 'Y', terminated by 0x0d 0x0a ( CR & LF )
<b>Example</b>	Y\r\n
<b>Response</b>	Y,Jan 30 2013,10:45:03,AL17\r\n B 00233 00000\r\n

N.B. This command returns two lines split by a carriage return line feed and terminated by a carriage return line feed. This command requires that the sensor has been stopped (see 'K' command).

## Low Power CO<sub>2</sub> Sensor

---

### CONNECTION DIAGRAM FOR UART INTERFACE

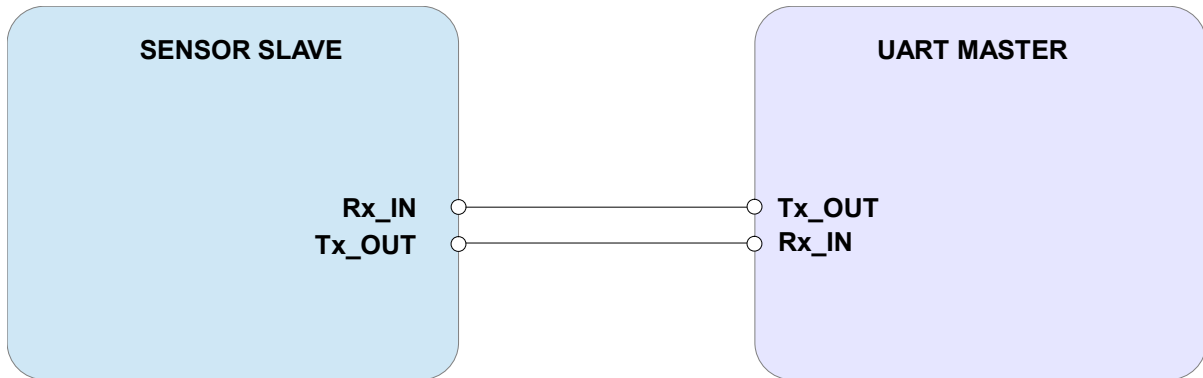

## Low Power CO<sub>2</sub> Sensor

---

### IMPORTANT NOTICE

Gas Sensing Solutions Ltd. (GSS) products and services are sold subject to GSS's terms and conditions of sale, delivery and payment supplied at the time of order acknowledgement. GSS warrants performance of its products to the specifications in effect at the date of shipment. GSS reserves the right to make changes to its products and specifications or to discontinue any product or service without notice.

Customers should therefore obtain the latest version of relevant information from GSS to verify that the information is current. Testing and other quality control techniques are utilised to the extent GSS deems necessary to support its warranty. Specific testing of all parameters of each device is not necessarily performed unless required by law or regulation. In order to minimise risks associated with customer applications, the customer must use adequate design and operating safeguards to minimise inherent or procedural hazards. GSS is not liable for applications assistance or customer product design. The customer is solely responsible for its selection and use of GSS products. GSS is not liable for such selection or use nor for use of any circuitry other than circuitry entirely embodied in a GSS product.

GSS products are not intended for use in life support systems, appliances, nuclear systems or systems where malfunction can reasonably be expected to result in personal injury, death or severe property or environmental damage. Any use of products by the customer for such purposes is at the customer's own risk.

GSS does not grant any licence (express or implied) under any patent right, copyright, mask work right or other intellectual property right of GSS covering or relating to any combination, machine, or process in which its products or services might be or are used. Any provision or publication of any third party's products or services does not constitute GSS's approval, licence, warranty or endorsement thereof. Any third-party trademarks contained in this document belong to the respective third-party owner.

Reproduction of information from GSS datasheets is permissible only if reproduction is without alteration and is accompanied by all associated copyright, proprietary and other notices (including this notice) and conditions. GSS is not liable for any unauthorised alteration of such information or for any reliance placed thereon.

Any representations made, warranties given, and/or liabilities accepted by any person which differ from those contained in this datasheet or in GSS's standard terms and conditions of sale, delivery and payment are made, given and/or accepted at that person's own risk. GSS is not liable for any such representations, warranties or liabilities or for any reliance placed thereon by any person.

### ADDRESS

Gas Sensing Solutions Ltd.  
Grayshill Road  
Cumbernauld  
G68 9HQ  
United Kingdom

## Low Power CO<sub>2</sub> Sensor

---

### REVISION HISTORY

DATE	RELEASE	DESCRIPTION OF CHANGES	PAGES
13/05/2020	4.0	First revision	All
25/05/2020	4.1	Changes to UART Interface Summary	P.27,29
04/06/2020	4.2	Changes to power consumption explanation	P.9
10/06/2020	4.3	Absolute maximum ratings	P.7
15/09/2020	4.4	Updated parametric table, updated READY pulse timings	P.9, P11-12
29/10/2020	4.5	Updated Control Interface Setup Timing	P.10,11
03/11/2020	4.6	Removed F command	P.28, 32, 33
07/01/2021	4.7	Electrical Characteristics	P.11